

# RESOLUCION DE ENCUENTRO DE PANELES

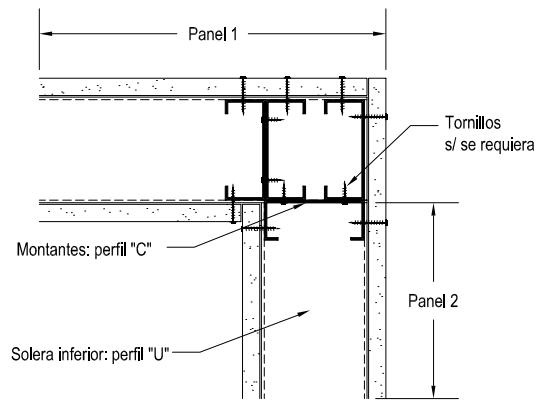

ENCUENTRO DE ESQUINA

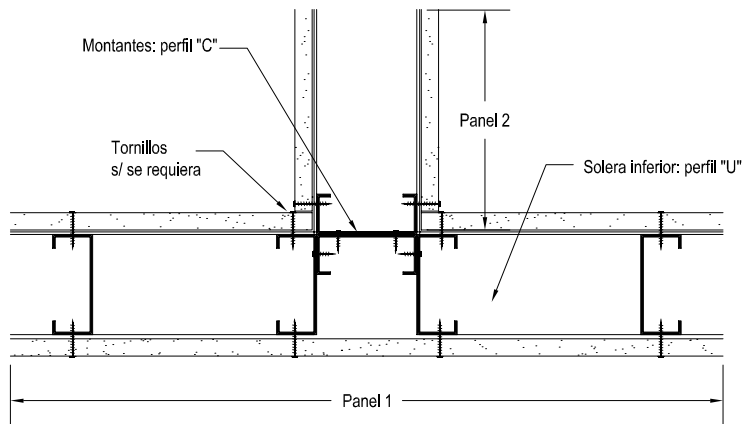
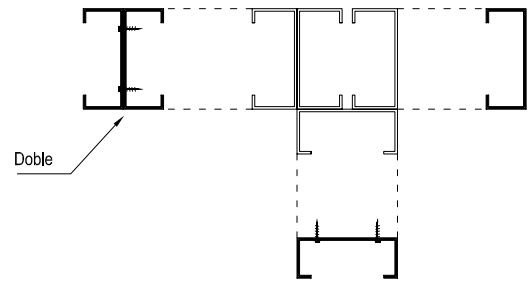

ENCUENTRO DE PANELES EN "T"

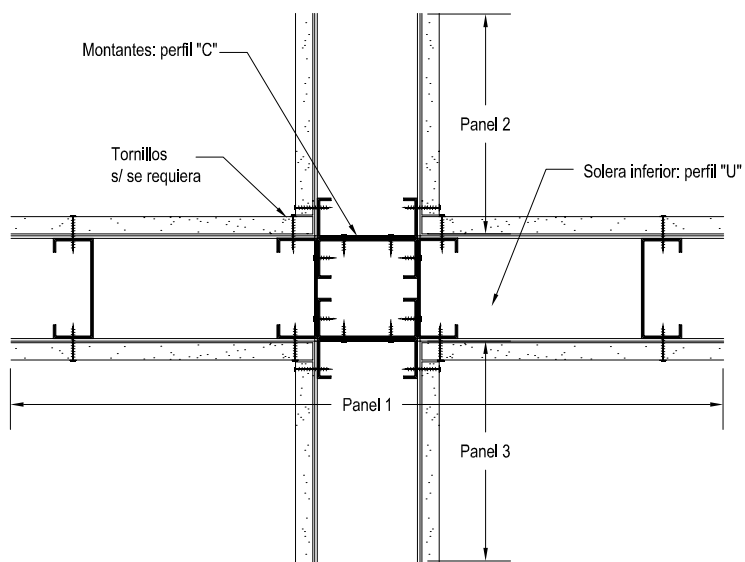
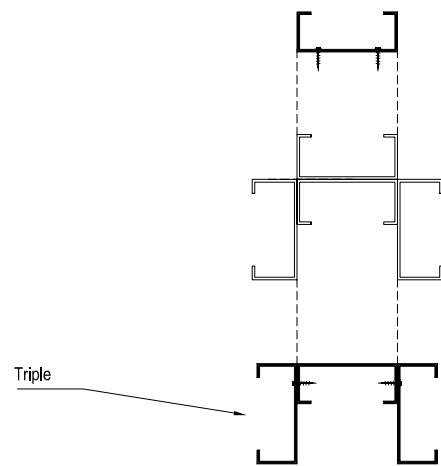

ENCUENTRO DE PANELES EN CRUZ

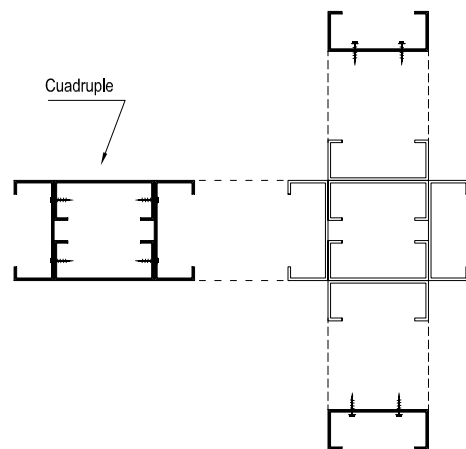

# PIEZAS CON MONTANTES

DOBLE

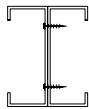

TRIPLE

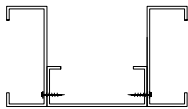

CUADRUPLE

